

2.1 WD615发动机/Engine

序号/ No.	名 称 / Designation	页 码 / Page No.
2.1.01	气缸体总成/Cylinder Block	1
2.1.02	气缸体(军车用)/Cylinder Block	2
2.1.03	飞轮壳及飞轮壳螺栓/Fly Wheel Housing	7
2.1.04	喷嘴总成(62、87)/Oil Nozzle	8
2.1.05	STEYR机油加油管组件(国II)/Tube assembly	9
2.1.06	曲轴和飞轮/Crankshaft and Flywheel	10
2.1.07	风扇装在水泵上的曲轴皮带轮(速比3/Belt pulley)	11
2.1.08	飞轮及飞轮螺栓/Flywheel and Bolt	12
2.1.09	活塞与连杆/Piston&Connecting rod	13
2.1.10	吊环夹紧块/Tighten Block	14
2.1.11	气缸盖/Cylinder Head	15
2.1.12	配气机构/Valve-Gear Mechanism	17
2.1.13	水泵和风扇/Water Pump and Fan	20
2.1.14	中间法兰(装刚性风扇)/Spacer flange	22
2.1.15	军车用发动机前支撑/Front mounting of engine	23
2.1.16	Φ590环形刚性风扇/Fan	24
2.1.17	欧II调温器总成(80度)/Temperature regulator assembly	25
2.1.18	双极机油泵/Oil Pump	26

2.1.19	供油系/Fuel Supply System	-----	28
2.1.20	燃油滤清器部分(M+h)/Fuel Filter	-----	31
2.1.21	起动机和发电机/Starter and Alternator	-----	33
2.1.22	传感器组(电子式机油压力传感器) / Sensor	-----	34
2.1.23	压气机进气管总成/Pipe	-----	35
2.1.24	进排气系统/Intake Manifold and Exhaust Manifold	-----	36
2.1.25	增压器进回油管总成/Turbocharger Tube	-----	39
2.1.26	中冷管及支架/Cooling pipe and Braket	-----	40
2.1.27	废气涡轮增压器/Turbocharger	-----	41
2.1.28	双缸水冷空压机/Air Compressor	-----	42
2.1.29	军车用油底壳/Oil Pan	-----	44

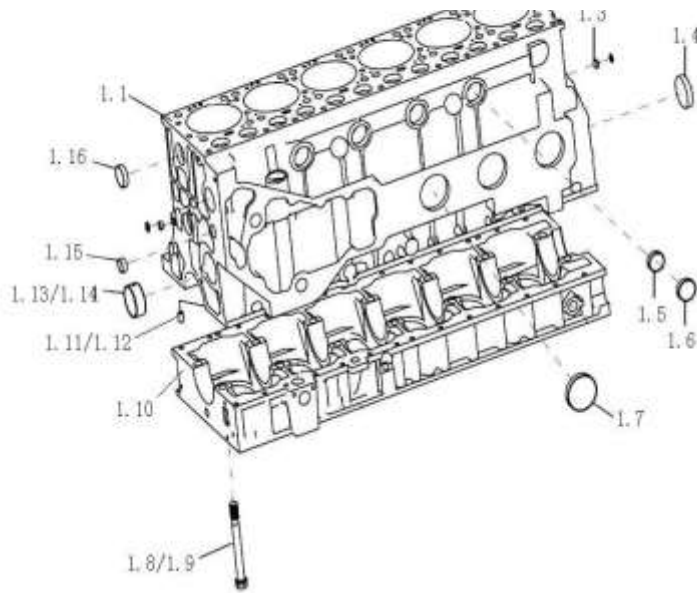

2.1.01 气缸体总成/Cylinder Block

序号 No.	零部件图号 Part No.	名称	Part Name	数量 Qty	备注 Remark
1	161500010386	气缸体总成	Cylinder block assembly	1	
1.1	61560010096	气缸体	Cylinder block	1	
1.2	VG1500010185	气缸盖螺栓	Bolt	21	
1.3	190003989480	碗形塞	Plug	1	
1.4	190003989288	碗形塞	Plug	1	
1.5	190003989289	碗形塞	Plug	4	
1.6	190003989215	碗形塞	Plug	3	
1.7	190003989210	碗形塞	Plug	6	
1.8	VG14010114	主轴承螺栓	Bolt	13	
1.9	VG14010217	主轴承螺栓	Bolt	1	
1.10	61500010366G	曲轴箱	Crankcase	1	
1.11	90003901604A	圆柱销	Pin	2	
1.12	Q5211220	园柱销	Pin	1	
1.13	VG1560010029	凸轮轴衬套	Bushing	5	
1.14	VG1096010010A	凸轮轴衬套	Bushing	1	
1.15	190003989204	碗形塞	Plug	1	
1.16	190003982121	碗形塞	Plug	4	

2.1.02 气缸体(军车用)/Cylinder Block

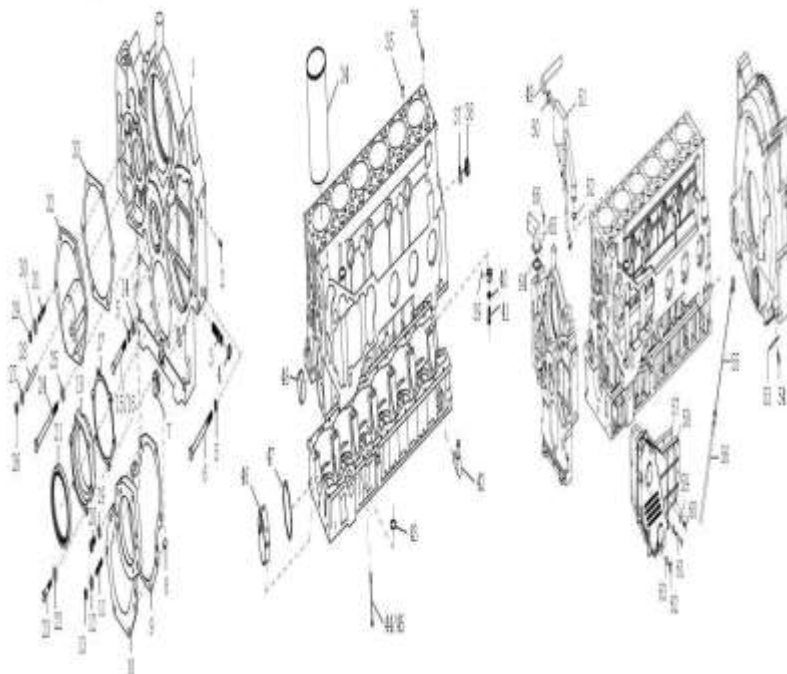

2.1.02 气缸体(军车用)/Cylinder Block

序号 No.	零部件图号 Part No.	名称	Part Name	数量 Qty	备注 Remark
1	61557010008	双缸空压机正时齿轮室	Gear case of dual-cylinder ai	1	
2	190003900085	弹性圆柱销	Pin	4	
3	190003813628	双头螺柱	Stud	8	
4	190003888453	2型全金属六角锁紧螺母	Nut	8	
5	190003931122	弹簧垫圈	Spring washer	10	
6	190003800566	六角头螺栓	Bolt	6	
7	190003962051	轻型六角头园柱螺塞	Plug	1	
8	190003901507	圆柱销	Pin	4	
9	VG14010070	凸轮轴齿轮盖垫片	Gasket	1	
10	VG1500010008A	凸轮轴齿轮盖	Cover	1	
11	190003813443	双头螺柱	Stud	1	
12	190003932023	波形弹性垫圈	Wave washer	6	
13	190003871252	1型六角螺母	Nut	6	
14	190003930271	平垫圈	Washer	2	
15	190003802523	六角头螺栓	Bolt	3	
16	190003800571	六角头螺栓	Bolt	1	
17	VG2600010934	前油封座垫片	Gasket	1	
18	VG2600010928	前油封座	Base	1	
19	190003932025	鞍形弹性垫圈	Washer	2	
20	190003862524	内六角圆柱头螺钉	Screw	2	

2.1.02 气缸体(军车用)/Cylinder Block

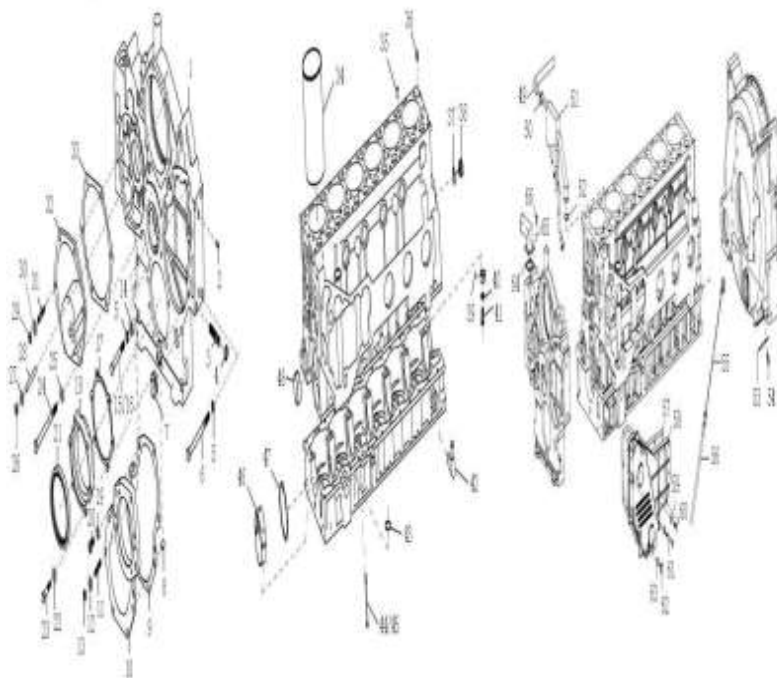

2.1.02 气缸体(军车用)/Cylinder Block

序号 No.	零部件图号 Part No.	名称	Part Name	数量 Qty	备注 Remark
21	VG1047010038	前油封	Oil seal	1	
22	VG9003080001	复合密封垫圈	Gasket	6	
23	190011260039	六角头螺栓	Bolt	6	
24	190003802576	六角头螺栓	Bolt	1	
25	190003932024	波形弹性垫圈	Wave washer	1	
26	190003871252	1型六角螺母	Nut	6	
27	190003932023	波形弹性垫圈	Wave washer	6	
28	190003813429	双头螺柱	Stud	3	
29	190003871252	1型六角螺母	Nut	5	
30	190003932023	波形弹性垫圈	Wave washer	5	
31	190003813429	双头螺柱	Stud	5	
32	VG2600010830	空压机齿轮盖	Cover	1	
33	VG14010040	空压机齿轮盖垫片	Gasket	1	
34	VG1540010006	气缸套	Cylinder liner	6	
35	190003901604	圆柱销	Pin	6	
36	190003909626	弹性圆柱销	Pin	6	
37	VG2600010735	复合垫圈	Gasket	1	
38	VG1460070011	主油道后螺塞	Plug	1	
39	190003909603	弹性圆柱销	Pin	6	
40	VG9003080005	复合密封垫圈	Gasket	6	

2.1.02 气缸体(军车用)/Cylinder Block

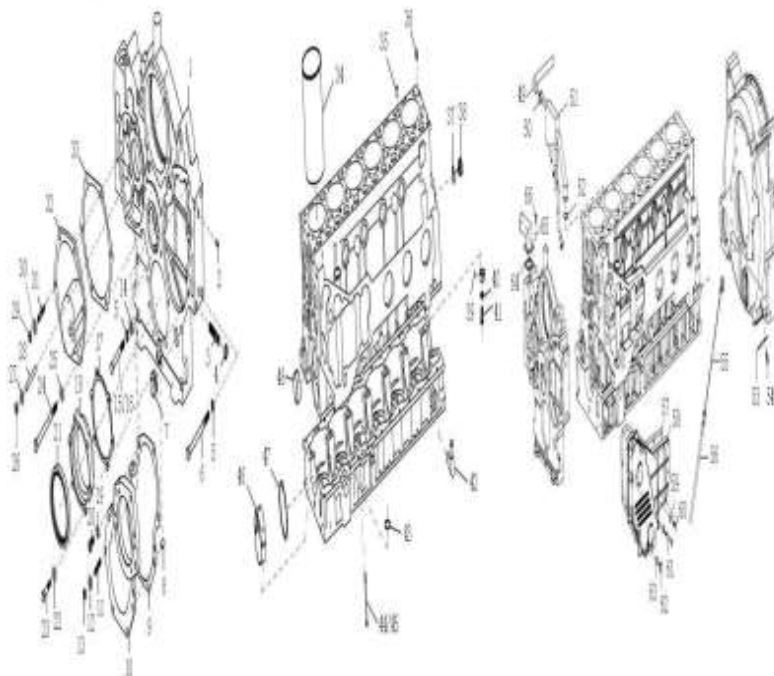

2.1.02 气缸体(军车用)/Cylinder Block

序号	零部件图号	名称	Part Name	数量	备注
No.	Part No.			Qty	Remark
41	190003962621	空心螺栓	Hollow bolt	6	
42	VG2600070097	回油弯管	Hose	1	
43	VG1400010032	密封圈	Gasket	2	
44	190003802493	六角头螺栓	Bolt	27	
45	190003932023	波形弹性垫圈	Wave washer	27	
46	VG1500010046	主轴瓦付	Bushing	7	
47	VG1500010125	止推片付	Shim assembly	2	20170907停用
47	VG1034010176	止推片付	Shim assembly	2	20170907启用
47.1	VG1034010177	止推片上片	Shim	1	
47.2	VG1034010178	止推片下片	Shim	1	
48	VG2600010990	凸轮轴衬套	Bushing	1	
49	VG12G00040038	带纤维夹层的橡胶软管	Hose	1	
50	190003989340	软管卡箍	Hose clamp	1	
51	VG1095010050	油气分离器总成	Oil separator	1	
52	Q734B2650265	O形橡胶密封圈	O-ring	1	
53	VG1800210011	观察孔盖	Cover	1	
54	190003802511	六角头螺栓	Bolt	2	
55	VG1500019205	软油尺油尺管总成		1	
55.1	VG2600010647	单管夹片	Clip	1	
55.2	VG2600010638	橡胶管箍		1	
56	VG2600010538A	油尺管堵		2	
57	VG1540010015A	机油冷却器盖垫片	Gasket	1	
58	VG1540010014A	机油冷却器盖	Cover	1	

2.1.02 气缸体(军车用)/Cylinder Block

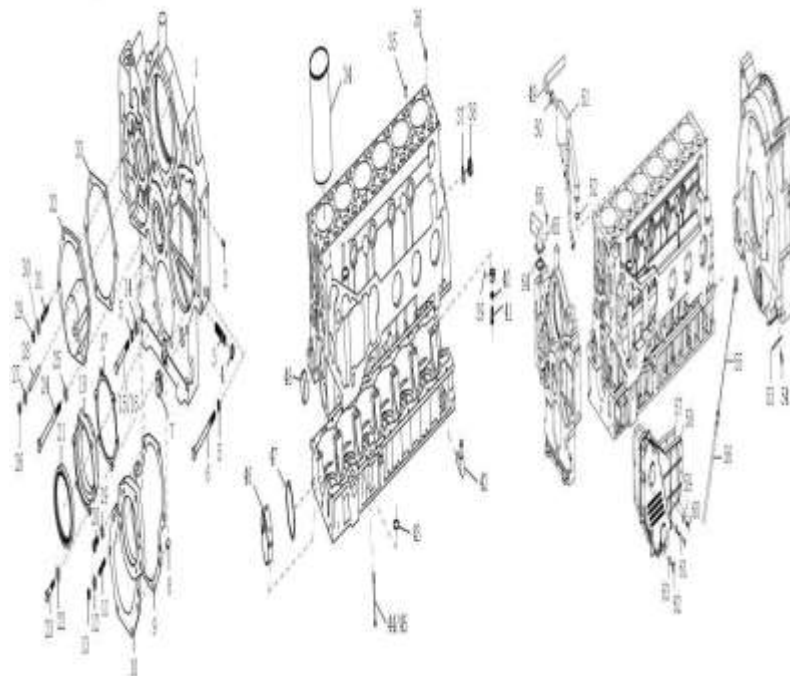

2.1.02 气缸体(军车用)/Cylinder Block

序号	零部件图号	名称	Part Name	数量	备注
No.	Part No.			Qty	Remark
59	190003932023	波形弹性垫圈	Wave washer	14	
60	190003802437	六角头螺栓	Bolt	6	
61	190003800467	六角头螺栓	Bolt	7	
62	VG9003080005	复合密封垫圈	Gasket	1	
63	190003962020	轻型六角头园柱螺塞	Plug	1	
64	VG14010086	加油短管垫片	Gasket	1	
65	190003931082	轻型弹簧垫圈	Spring washer	4	
66	190003802321	六角头螺栓	Bolt	4	
67	VG61000010134	密封圈	Gasket	1	
68	190003813429	双头螺柱	Stud	1	
69	190003989336	软管卡箍	Hose clamp	2	
70	VG609E110049	固定板	Plate	1	
71	VG2600010735	复合垫圈	Gasket	1	
72	190003901604	圆柱销	Pin	2	
73	190003931122	弹簧垫圈	Spring washer	12	
74	190003813527	双头螺柱	Stud	3	
75	190003888452	2型全金属六角锁紧螺母	Nut	3	
76	VG9003080007	复合密封垫圈	Gasket	1	
77	190003802321	六角头螺栓	Bolt	1	
78	190003936101	垫圈	Washer	1	

2.1.02 气缸体(军车用)/Cylinder Block

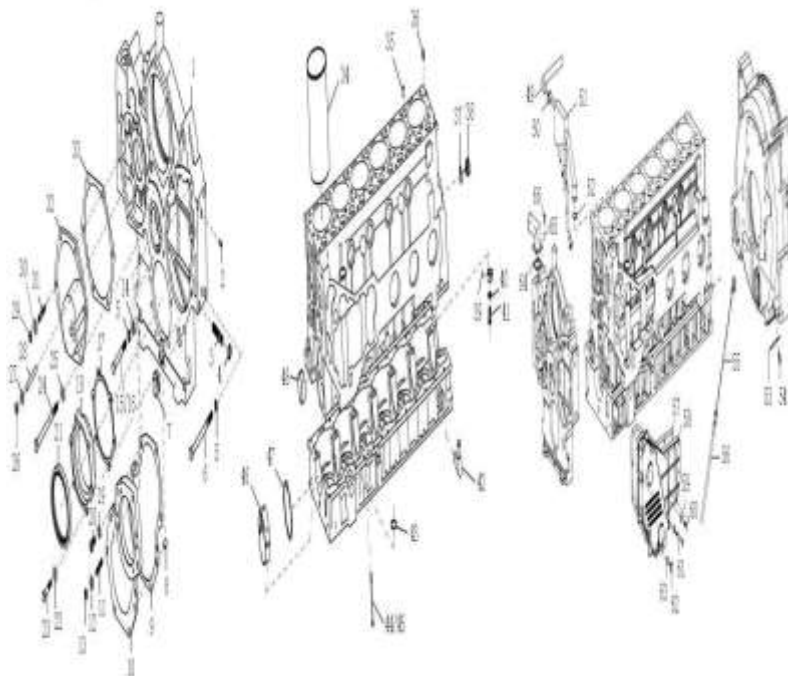

2.1.02 气缸体(军车用)/Cylinder Block

序号	零部件图号	名称	Part Name	数量	备注
No.	Part No.			Qty	Remark
79	190003931082	轻型弹簧垫圈	Spring washer	1	
80	190003989336	软管卡箍	Hose clamp	2	
81	VG2600010193	铭牌	Name plate	1	
82	VG2600010447	单管夹子	Clip	1	
83	VG2600010446	机油标尺的橡胶软管	Hose	1	
84	VG1500010031	支撑块	Block	1	
85	190003802411	六角头螺栓	Bolt	1	
86	VG2600010445	单管夹子	Clip	1	
87	190003802511	六角头螺栓	Bolt	1	
88	190003931122	弹簧垫圈	Spring washer	1	
89	190003930271	平垫圈	Washer	1	
90	VG2600010791	标牌铆钉	Rivet	4	
91	VG288730061	O型密封圈	O-ring	1	
92	190003802419	六角头螺栓	Bolt	2	
93	190003932023	波形弹性垫圈	Wave washer	2	
94	VG1047010050	后油封总成(迷宫式)	Oil seal	1	
95	90003989301	软管卡箍		2	
96	VG407010046	密封圈	Gasket	1	
97	190003989480	碗形塞	Plug	1	
98	VG1500010175	橡胶软管	Hose	1	

2.1.06 曲轴和飞轮/Crankshaft and Flywheel

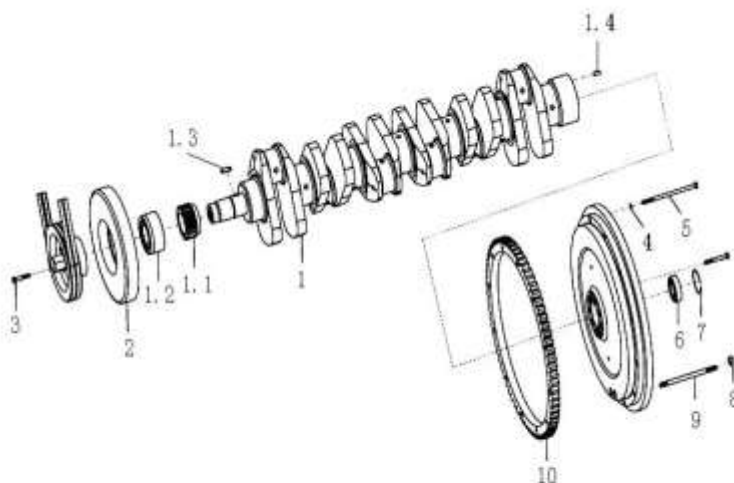

2.1.06 曲轴和飞轮/Crankshaft and Flywheel

序号 No.	零部件图号 Part No.	名称	Part Name	数量 Qty	备注 Remark
1	161500020071	曲轴总成		1	
1.1	VG14020038	曲轴齿轮	Crankshaft gear	1	
1.2	VG1500020070	法兰	Flange	1	
1.3	Q5510828	普通平键	Key	1	
1.4	190003901418	圆柱销	Pin	1	
1.5	VG2600020311	堵塞	Plug	6	
2	VG1540020003	减振器	Shock absorber	1	
3	190003802558	六角头螺栓	Bolt	8	
4	190003932024	波形弹性垫圈	Wave washer	12	
5	190003800579	六角头螺栓	Bolt	10	
6	190003311416	球轴承	Ball bearing	1	
7	190003934310	孔用弹性挡圈	Circlip	1	
8	190003871305	1型六角螺母	Nut	2	
9	190003813571	双头螺柱	Stud	2	
10	VG2600020208	飞轮齿圈	Flywheel ring gear	1	

2.1.09 活塞与连杆/Piston&Connecting rod

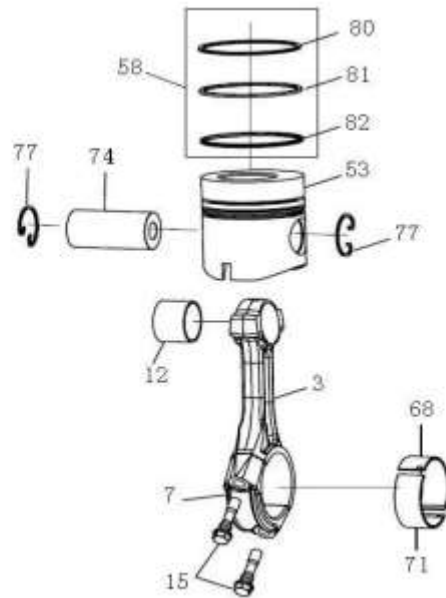

2.1.09 活塞与连杆/Piston&Connecting rod

序号	零部件图号	名称	Part Name	数量	备注
No.	Part No.			Qty	Remark
0	161500030009	连杆总成	Connecting rod assembly	6	
3	161500030008	连杆体	Connecting rod	1	
7	161500030022	连杆盖	Cover	1	
12	VG1500030077	连杆衬套	Bushing	1	
15	VG1500030023	连杆螺栓	Bolt	2	
53	VG1560030010	活塞总成	Piston assembly	6	
58	VG1560030050	活塞环组	Rings	1	
68	VG1560037034	连杆轴瓦上瓦	Bushing	6	
71	VG1560037033	连杆轴瓦下瓦	Bushing	6	
74	VG1560030013	活塞销	Pin	6	
77	VG1560030012	活塞销挡圈	Circlip	12	
79	VG1047030051	活塞环组 (E008)	Piston Ring Set	6	
80	VG1540030007	梯形桶面环	Ring	1	
81	VG1540030006	锥面环	Ring	1	
82	VG1560030045	油环	Oil ring	1	

2.1.11 气缸盖/Cylinder Head

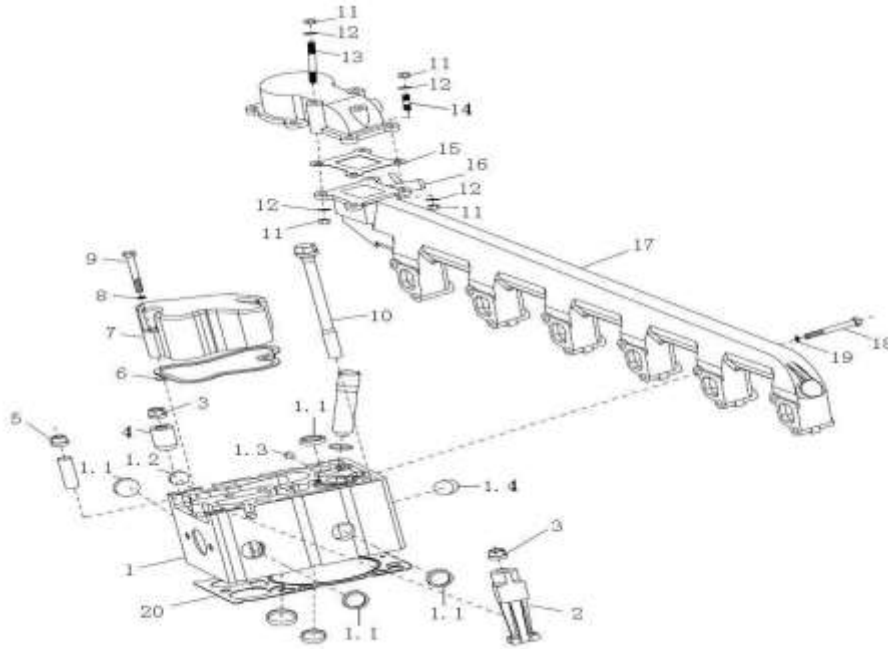

2.1.11 气缸盖/Cylinder Head

序号	零部件图号	名称	Part Name	数量	备注
No.	Part No.			Qty	Remark
1	61560040068	气缸盖总成	Cylinder head assembly	6	
1.1	190003989294	碗形塞片	Shim	4	
1.2	190003989721	碗形塞片	Shim	1	
1.3	190003989277	碗形塞片	Shim	1	
1.4	190003989725	碗形塞片	Shim	1	
2	VG1200040027	夹紧块	Block	2	
3	VG1200040034	带肩螺母	Nut	21	
4	VG1200040023A	夹紧块	Block	5	
5	VG1560040032	气门杆密封套	Sleeve	12	
6	VG14040021	气缸盖罩衬垫	Gasket	6	
7	VG1500040066	气缸盖罩	Cylinder Head Cover	6	
8	190003800466	六角头螺栓	Bolt	12	
9	190003932023	波形弹性垫圈	Wave washer	12	
10	VG1500040023	气缸盖主螺栓	Bolt	24	
11	190003871252	1型六角螺母	Nut	4	
12	190014040007	平垫圈	Washer	4	
13	190003813467	双头螺柱	Stud	2	
14	190003813429	双头螺柱	Stud	2	
15	VG1500040106	出水管接管垫片	Gasket	1	
16	VG1500060045A	管子接头	Nozzle assembly	1	

2.1.12 配气机构/Valve-Gear Mechanism

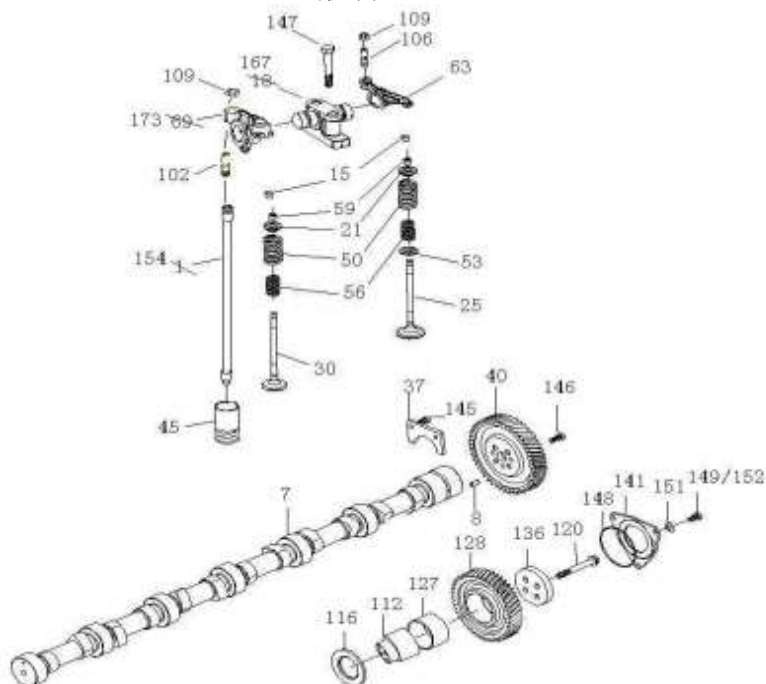

2.1.12 配气机构/Valve-Gear Mechanism

序号 No.	零部件图号 Part No.	名称	Part Name	数量 Qty	备注 Remark
5	VG1500050097A	凸轮轴总成	Camshaft assembly	1	2014年6月15日后
5	VG1500050097	凸轮轴总成	Camshaft assembly	1	2014年6月15日停
7	VG1500050096A	凸轮轴	Camshaft	1	2014年6月15日后
7	VG1500050096	凸轮轴	Camshaft	1	2014年6月15日停
8	190003901409	圆柱销	Pin	1	
15	VG1500050105	气门帽	Valve cap	12	
21	VG1500050109	气门弹簧上座	Base	12	
25	VG1560051001	进气门	Inlet valve	6	
30	VG1560050027	排气门	Exhaust valve	6	
37	VG14050133	凸轮轴止推片	Shim	1	
40	VG14050053	凸轮轴正时齿轮	Camshaft timing gear	1	
45	VG1500050032	气门挺柱	Valve tappet	12	
50	VG1500050002	气门外弹簧	Valve spring	12	
53	VG14050017	进气门弹簧下座	Spring base	6	
56	VG1500050001	气门内弹簧	Valve spring	12	
59	VG1500050025	气门锁夹	Clip	24	
63	VG14050048	进气门摇臂	Rocker arm	6	
72	VG1500050043	排气门摇臂	Rocker arm	1	
74	VG1500050037	堵	Plug	1	
76	VG1500050038	堵	Plug	3	
102	VG1500050017	气门间隙调整螺钉	Screw	6	
106	VG14050010	气门间隙调整螺钉	Screw	6	

2.1.12 配气机构/Valve-Gear Mechanism

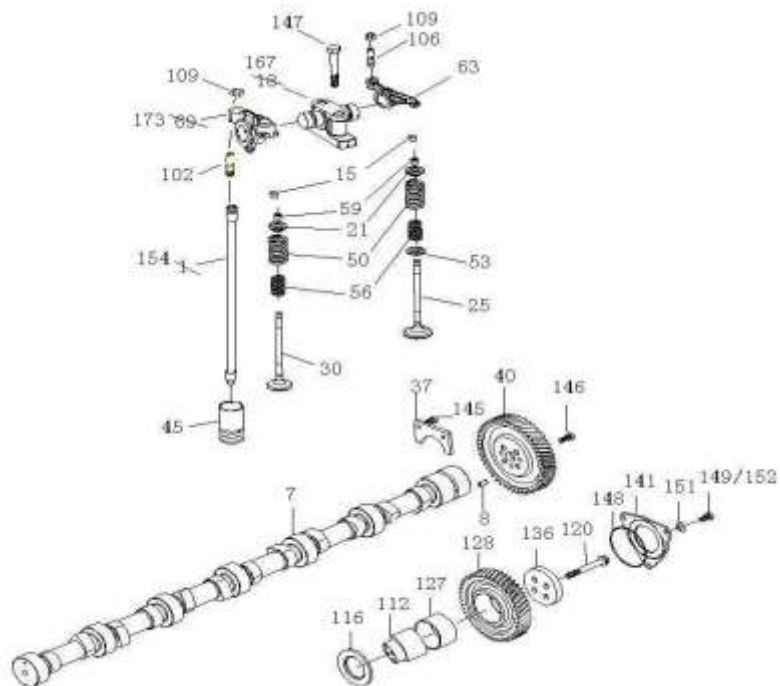

2.1.12 配气机构/Valve-Gear Mechanism

序号 No.	零部件图号 Part No.	名称 Name	Part Name	数量 Qty	备注 Remark
109	VG2130050065	气门间隙调整螺母	Nut	18	
112	VG1540059031	中间齿轮轴	Shaft	1	
116	VG1540059032	中间齿轮垫片	Gasket	1	
120	VG1560050059	六角头螺栓	Bolt	4	
125	VG1560050053	中间齿轮总成	Gear assembly	1	
127	VG1560050054	衬套	Bushing	1	
128	VG1560050052	中间齿轮	Gear	1	
136	VG1560050045	挡板	Plate	1	
141	VG1560050046A	盖板	Cover	1	
145	190003802399	六角头螺栓	Bolt	2	
146	190003802443	六角头螺栓	Bolt	4	
148	190003120602	密封圈	Gasket	1	
149	190003813414	双头螺柱	Stud	2	
150	190003871252	1型六角螺母	Nut	2	
151	190003932023	波形弹性垫圈	Wave washer	3	
152	190003862419	内六角圆柱头螺钉	Screw	1	
153	61500050030	EVB排气门间隙调整规范	Clearance adjusting standard	1	
154	VG1092050020	气门推杆总成	Push rod assembly	12	
156	VG1092050019	气门推杆杆身	Rod	1	
157	VG1096050031	气门推杆凹头	Head	1	

2.1.12 配气机构/Valve-Gear Mechanism

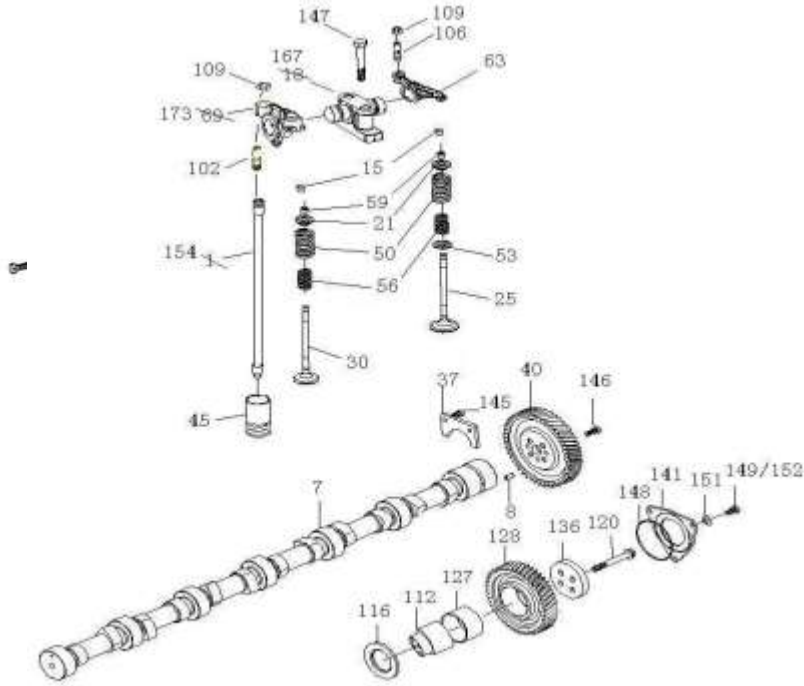

2.1.12 配气机构/Valve-Gear Mechanism

序号 No.	零部件图号 Part No.	名称	Part Name	数量 Qty	备注 Remark
158	VG1096050033	气门推杆球头	Ball joint	1	
167	VG1500050120	气门摇臂座	Rocker arm base	6	
173	VG1500050030	排气门摇臂组件	Rocker arm parts	6	
175	VG1500050031	排气门摇臂总成	Rocker arm assembly	1	
176	VG1500050033	排气门摇臂	Rocker arm	1	
179	VG1500050034	排气门摇臂活塞	Rocker arm piston	1	
181	VG1500050035	摇臂活塞弹簧	Piston spring	1	
183	VG1500050036	球阀弹簧	Ball spring	1	
184	190016220001	滚针	Needle	1	
185	190016210015	钢球	Ball	1	
210	VG1500050121	压紧块	Block	6	
213	VG1500050011	调节螺钉总成	Adjusting screw ass.	6	
215	VG1500050012	调节螺钉	Adjusting screw	1	
216	VG1500050013	圆球座	Ball seat	1	
220	Q150B12100TF2	六角头螺栓	Bolt	12	

2.1.13 水泵和风扇/ water Pump and Fan

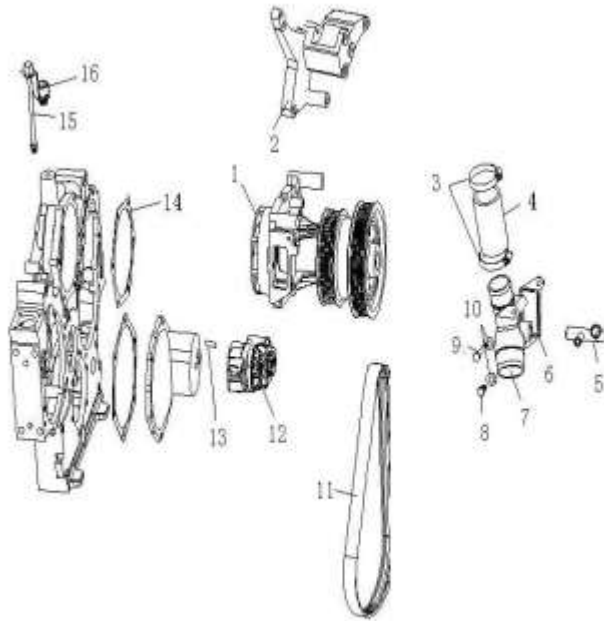

2.1.13 水泵和风扇/ water Pump and Fan

序号 No.	零部件图号 Part No.	名称	Part Name	数量 Qty	备注 Remark
1	VG1500060051	水泵总成	Water pump assembly	1	
2	VG1500130018A	空调托架	Bracket	1	
3	190003989308	软管卡箍	Hose clamp	2	
4	VG61000060276	胶管	Hose	1	
5	VG1560060004	回水管接头组件	Nozzle assembly	1	
6	VG14060024	水管接头垫片	Gasket	1	
7	VG1560060023	水管接头	Nozzle	1	
8	190003802424	六角头螺栓	Bolt	1	
9	190003800467	六角头螺栓	Bolt	1	
10	190003932023	波形弹性垫圈	Wave washer	2	
11	VG1069020010	汽车多楔带	Belt	1	
12	VG2600060313	自动张紧轮	Tensioner	1	
13	Q5211022	圆柱销	Pin	1	
14	VG140608	水泵密封垫	Gasket	1	
15	VG2600060460	水泵加黄油装置	Grease nipple	1	
16	Q218B1625	内六角圆柱头螺钉	Screw	1	
17	190003802424	六角头螺栓	Bolt	6	
18	190003888451	2型全金属六角锁紧螺母	Nut	6	
19	190003802432	六角头螺栓	Bolt	1	
20	190014040007	平垫圈	Washer	1	

2.1.18 双极机油泵/Oil Pump

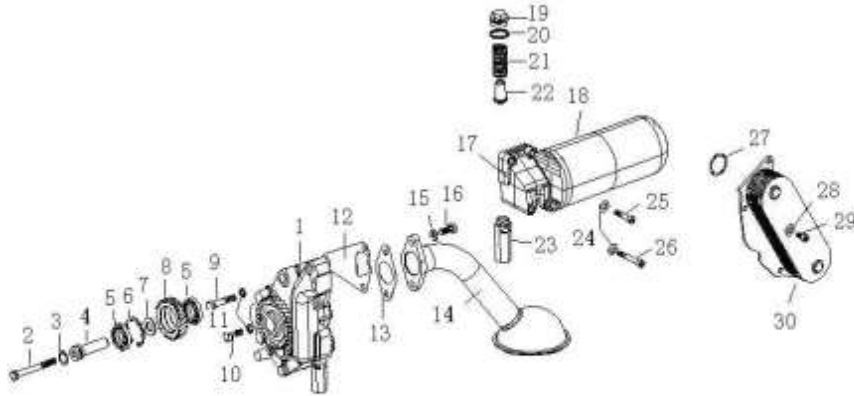

2.1.18 双极机油泵/Oil Pump

序号	零部件图号	名称	Part Name	数量	备注
No.	Part No.			Qty	Remark
1	VG1500070067	双级机油泵总成	Oil Pump	1	
2	190003802578	六角头螺栓	Bolt	1	
3	VG14070155	密封圈	Gasket	1	
4	VG14070056	中间齿轮轴	Shaft	1	
5	190003311410	向心球轴承	Ball bearing	2	
6	190003934732	带凸齿的孔用挡圈	Circlip	1	
7	VG14070049	中间隔圈	Spacer	1	
8	VG14070061	机油泵中间齿轮	Gear	1	
9	190003800551	六角头螺栓	Bolt	1	
10	190003802527	六角头螺栓	Bolt	1	
11	190003932025	鞍形弹性垫圈	Washer	2	
12	VG14070055	机油泵垫片	Gasket	1	
13	VG140778	垫片	Shim	2	
14	VG1500070082	集滤器总成	Oil filter assembly	1	
15	190003932025	鞍形弹性垫圈	Washer	2	
16	190003802523	六角头螺栓	Bolt	2	
17	VG1500070051	机油滤清器底座组件	Oil filter base assembly	1	
18	VG61000070005	旋装式机油滤芯总成	Oil filter element assembly	2	
19	190003962051	轻型六角头园柱螺塞	Plug	1	
20	VG2600010735	复合垫圈	Gasket	1	

2.1.18 双极机油泵/Oil Pump

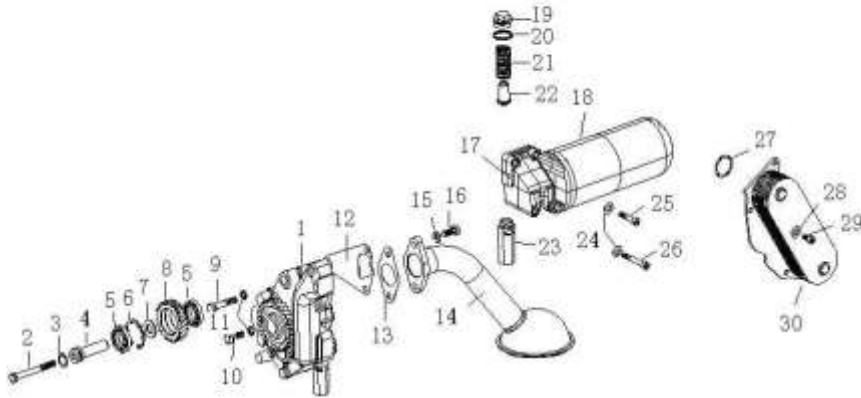

2.1.18 双极机油泵/Oil Pump

序号	零部件图号	名称	Part Name	数量	备注
No.	Part No.			Qty	Remark
21	VG14070068	安全阀弹簧	Spring	1	
22	VG14070069	安全阀	Relief valve	1	
23	VG1500070097	主油道限压阀总成	Valve	1	
24	190003932023	波形弹性垫圈	Wave washer	4	
25	190003862443	内六角圆柱头螺钉	Screw	2	
26	190003862482	园柱头内六角螺钉	Screw	2	
27	VG1400010032	密封圈	Gasket	2	
28	190003932023	波形弹性垫圈	Wave washer	4	
29	190003862419	内六角圆柱头螺钉	Screw	4	
30	VG1500010334	机油冷却器(8片)	Oil cooler	1	
31	VG14070198	吸油管总成	Oil pipe	1	
32	VG1500079001	垫圈	Washer	1	
33	Q150B0620	六角头螺栓	Bolt	1	
34	Q41806	波形垫片	Shim	1	

2.1.19 供油系/Fuel Supply System

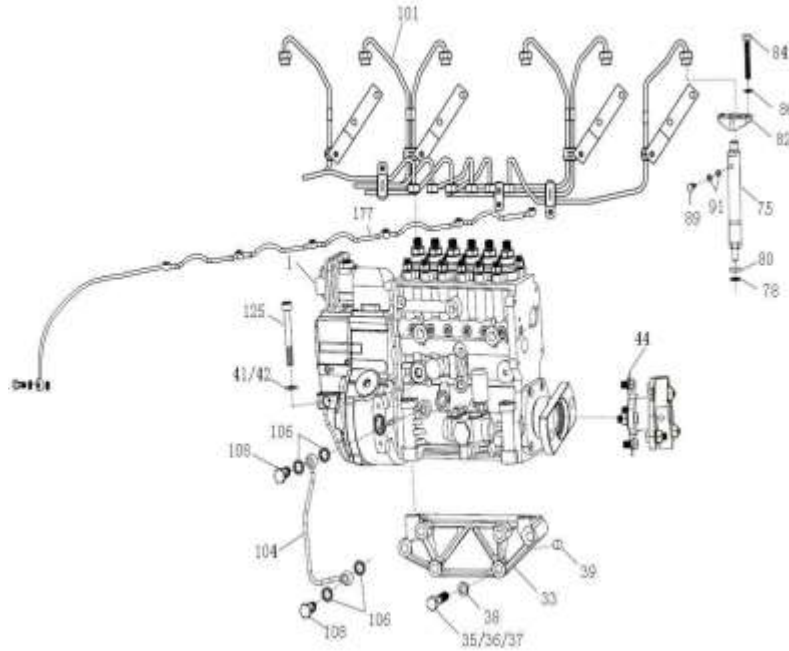

2.1.19 供油系/Fuel Supply System

序号 No.	零部件图号 Part No.	名称	Part Name	数量 Qty	备注 Remark
1	VG1560080020	国产高压喷油泵带K型调速	Injection pump ass.	1	
33	VG1500080174	喷油泵托架	Bracket	1	
35	Q150B1295	六角头螺栓	Bolt	3	
36	Q150B1285	六角头螺栓	Bolt	1	
37	Q150B1245	六角头螺栓	Bolt	2	
38	190003931142	弹簧垫圈	Spring washer	6	
39	190003901600	圆柱销	Pin	2	
41	190003930271	平垫圈	Washer	4	
42	VG18872339	自锁垫圈	Washer	4	
44	VG1560080300	联轴器总成	Coupling assembly	1	
46	VG1560080279	联轴器法兰组件	Flange components	1	
47	VG1560080266	法兰	Flange	2	
48	VG1560080270	连接管	Pipe	1	
49	VG1560080219	弹性连接片	Spring piece	12	
50	VG1560080273	衬套	Bushing	8	
51	Q40012T16F9	小垫圈	Washer	8	
52	VG1560080271	垫圈	Washer	8	
53	Q150B1250TF2	六角头螺栓	Bolt	2	
54	Q150B1235TF2	六角头螺栓	Bolt	4	
55	Q150B1240TF2	六角头螺栓	Bolt	2	

2.1.19 供油系/Fuel Supply System

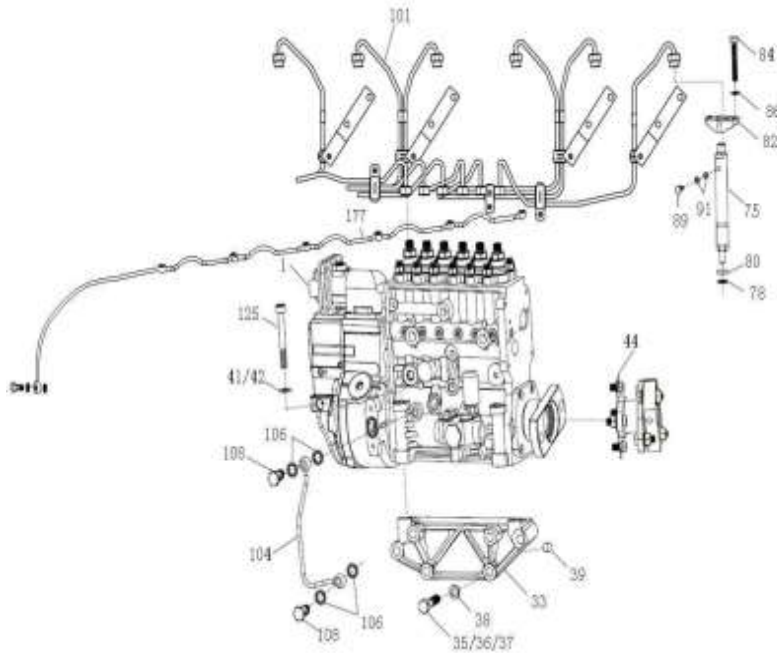

2.1.19 供油系/Fuel Supply System

序号 No.	零部件图号 Part No.	名称	Part Name	数量 Qty	备注 Remark
56	Q340B12T13F2	1型六角螺母	Nut	8	
57	VG1560080194	角度调节板	Plate	1	
58	VG1560080001	六角头螺栓	Bolt	1	
75	VG1560080305	喷油器总成	Fuel injector	6	
78	VG14080082	垫圈	Washer	6	
80	VG609070080	密封垫圈	Gasket	6	
82	VG1500080094A	紧固压板	Plate	6	
84	VG2600080383	六角头螺栓	Bolt	12	
86	190003932023	波形弹性垫圈	Wave washer	12	
89	VG1500080090	空心螺栓	Hollow bolt	6	
91	VG9003080001	复合密封垫圈	Gasket	12	
96	190003171697	塑料紧箍带	Cable binder	2	
97	190003171356	塑料紧固带A5*280	Cable binder	2	
101	VG1560080278A	高压油管组	Injection tube assembly	1	
103	VG1560080172	支承架	Bracket	1	
104	VG1560070025	润滑油回油管总成	Tube assembly	1	
106	VG2600080200	密封垫圈	Gasket	2	
108	190003962621	空心螺栓	Hollow bolt	1	
109	VG1560080284	空气管	Tube	1	
111	190003962612	空心螺栓	Hollow bolt	1	

2.1.19 供油系/Fuel Supply System

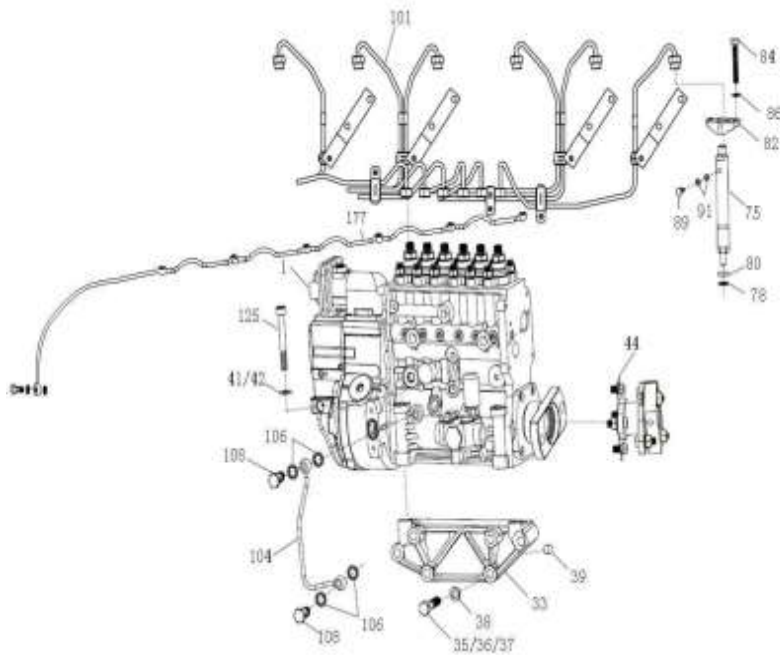

2.1.19 供油系/Fuel Supply System

序号 No.	零部件图号 Part No.	名称	Part Name	数量 Qty	备注 Remark
112	VG9003080004	复合密封垫圈	Gasket	2	
113	VG1095088010	输油泵总成	Fuel pump	1	
114	VG1095088015	溢油阀总成	Valve	1	
115	VG1095088019	修理包	Repair bag	1	
116	VG1095088021	油封	Oil seal	1	
117	VG1095088022	出油阀紧座	Delivery valve base	1	
118	VG1095088024	烟限器总成	Smoke limiter	1	
119	VG1095088026	调盖总成	Cover	1	
120	VG1095088028	调速器壳体	Housing	1	
121	VG1095088030	飞块及支架总成	Flyweight and bracket assem	1	
125	190003800571	六角头螺栓	Bolt	4	
139	VG1095088006	油嘴	Nozzle	1	
140	VG1095088002	柱塞偶件	Plunger assembly	1	
141	VG1095088004	出油阀偶件	Delivery valve assembly	1	
177	VG1500080095A	回油管总成	Tube assembly	1	

2.1.20 燃油滤清器部分 (M+h)/Fuel Filter

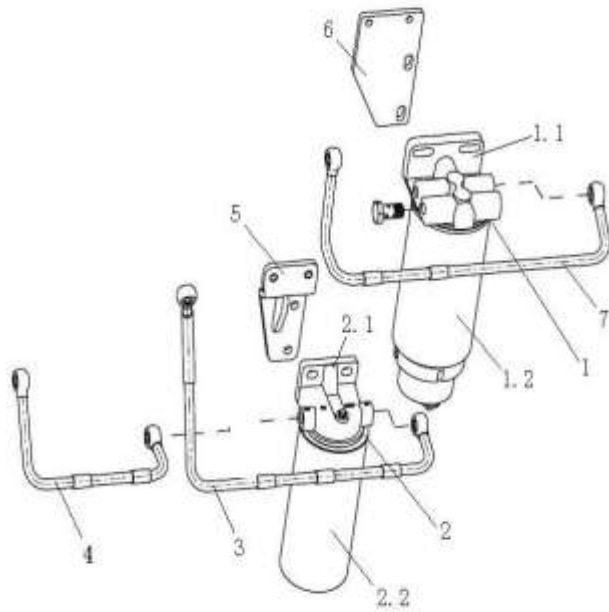

2.1.20 燃油滤清器部分 (M+h)/Fuel Filter

序号	零部件图号	名称	Part Name	数量	备注
No.	Part No.			Qty	Remark
1	VG1560080016	旋装式燃油粗滤器总成	Fuel primary filter assembly	1	
1.1	VG1560080014	旋装式燃油粗滤器滤座	Base	1	
1.2	VG1047080011	滤芯和滤杯总成	Filter and cup assembly	1	
1.2.1	VG1540080311	旋装式燃油粗滤器	Fuel primary filter	1	
1.2.2	VG1047080009	燃油粗滤器水杯	Fuel coarse filte cup	1	
2	VG1560080011	旋装式燃油精滤器总成	Fuel fine filter assembly	1	
2.1	VG1560080013	旋装式燃油精滤器滤座	Base	1	
2.2	VG1560080012	旋装式燃油精滤器	Fuel fine filter assembly	1	
3	VG1092080017	燃油管总成	Fuel Tube	1	
4	VG1092080018	燃油管总成	Fuel Tube	1	
5	VG1092080026	燃油精滤器托架	Bracket	1	
6	VG1540080027	粗滤支架	Bracket	1	
7	VG1092080019	燃油管总成	Fuel Tube	1	
8	190003802527	六角头螺栓	Bolt	2	
9	190003931122	弹簧垫圈	Spring washer	2	
10	190003935009	平垫圈	Washer	2	
11	190003802523	六角头螺栓	Bolt	2	
12	190003932024	波形弹性垫圈	Wave washer	2	
13	190003930012	大垫圈	Washer	2	
14	VG2600080200	密封垫圈	Gasket	4	

2.1.21 起动机和发电机/Starter and Alternator

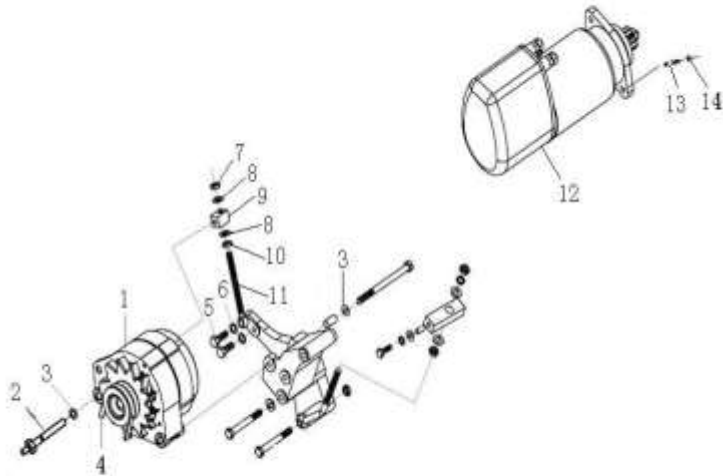

2.1.21 起动机和发电机/Starter and Alternator

序号 No.	零部件图号 Part No.	名称	Part Name	数量 Qty	备注 Remark
1	VG1095094002	28V/70A交流发电机	Alternator-1540W	1	
2	VG1092094001	发电机双头螺柱	Stud	1	
3	190003932025	鞍形弹性垫圈	Washer	1	
4	VG2600020258	汽车多楔带	Belt	1	
5	Q150B1055	六角头螺栓	Bolt	1	
6	190003930271	平垫圈	Washer	1	
7	190003888452	2型全金属六角锁紧螺母	Nut	1	
8	190003930271	平垫圈	Washer	2	
9	VG1500090045	拉紧块(2KW发电机用)	Block	1	
10	VG1500090048	六角螺母(发电机用)	Nut	1	
11	VG1500090046	拉紧螺栓	Bolt	1	
12	VG1560090001	减速型起动机	Starter	1	
13	190003813532	双头螺柱	Stud	3	
14	190003888452	2型全金属六角锁紧螺母	Nut	3	
15	VG2600090288	压紧块	Block	1	
16	190003800568	六角头螺栓	Bolt	1	
17	190003932025	鞍形弹性垫圈	Washer	1	
18	VG1092094002	间隔块	Block	1	

2.1.22 传感器组(电子式机油压力传感器) / Sensor

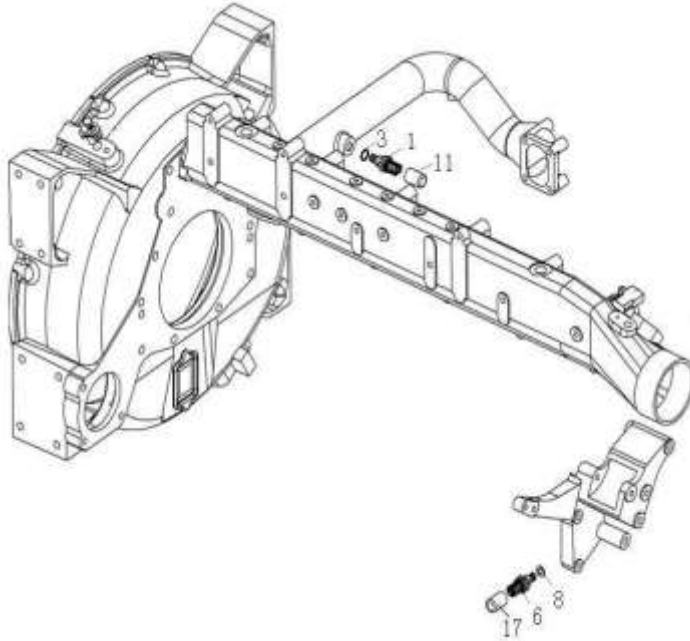

2.1.22 传感器组(电子式机油压力传感器) / Sensor

序号 No.	零部件图号 Part No.	名称	Part Name	数量 Qty	备注 Remark
1	VG1500090061	水温表传感器	Water temperature sensor	1	
3	VG9003080005	复合密封垫圈	Gasket	1	
6	VG1092090311	电子机油压力传感器	Oil pressure sensor	1	
8	VG2600080275	复合密封垫圈	Gasket	1	
11	VG2600090318	水温传感器罩	Cover	1	
17	VG1095090139	机油压力传感器罩	Cover	1	
2	VG1500090061	水温表传感器	Water temperature sensor	1	
4	VG9003080005	复合密封垫圈	Gasket	1	
5	VG9003080005	复合密封垫圈	Gasket	1	
7	VG1092090311	电子式机油压力传感器	Oil pressure sensor	1	
9	VG2600080275	复合密封垫圈	Gasket	1	
10	VG2600080275	复合密封垫圈	Gasket	1	
12	VG2600090318	水温传感器罩	Water temperature sensor	1	
13	VG2600090318	水温传感器罩	Water temperature sensor	1	
18	VG1095090139	机油压力传感器罩	Cover	1	
19	VG1095090139	机油压力传感器罩	Cover	1	

2.1.24 进排气系统/Intake Manifold and Exhaust Manifold

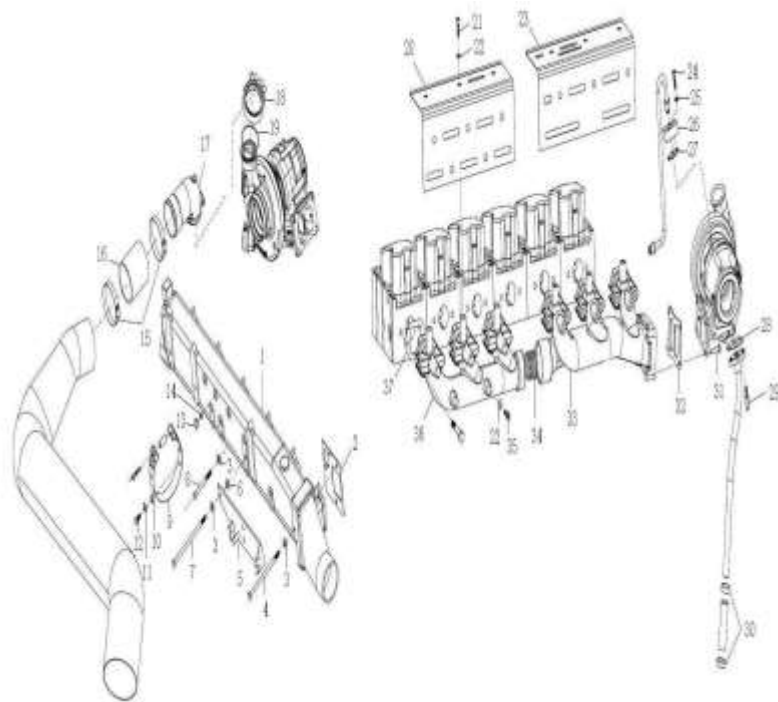

2.1.24 进排气系统/Intake Manifold and Exhaust Manifold

序号 No.	零部件图号 Part No.	名称	Part Name	数量 Qty	备注 Remark
1	VG2600110810	进气管总成		1	
1.1	VG2600110455	盖板	Cover	1	
1.2	VG2600110456	垫片	Shim	1	
1.3	190003931102	弹簧垫圈	Spring washer	3	
1.4	190003802432	六角头螺栓	Bolt	3	
1.5	190003098010	密封垫圈	Gasket	1	
1.6	190017020001	六角头螺塞	Plug	1	
1.7	190017020002	六角头螺塞	Plug	2	
1.8	190003098020	平垫圈	Washer	2	
2	VG1500110024	进气管垫片	Gasket	6	
3	190003932023	波形弹性垫圈	Wave washer	12	
4	VG14110064	进气管紧固螺栓	Bolt	4	
5	VG9100570019	悬臂总成		1	
6	VG609E110036	调整垫圈	Washer	2	
7	190003800497	六角头螺栓--螺栓GB5782	Bolt	2	
8	190003800465	六角头螺栓	Bolt	6	
9	VG1560110021	卡箍带	Clamp	2	
10	VG609E110036	调整垫圈	Washer	2	
11	190003932023	波形弹性垫圈	Wave washer	2	
12	Q218B0815	内六角圆柱头螺钉	Screw	2	

2.1.24 进排气系统/Intake Manifold and Exhaust Manifold

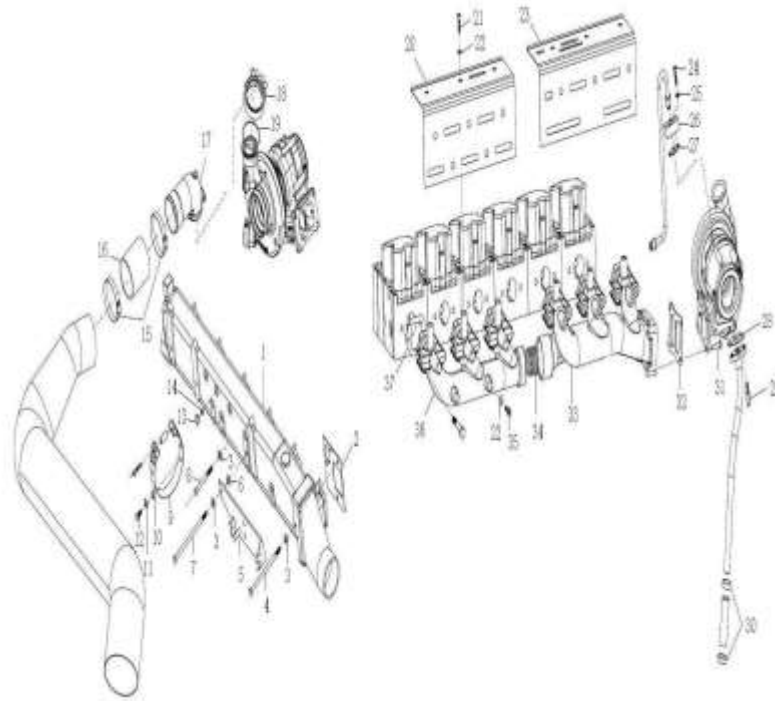

2.1.24 进排气系统/Intake Manifold and Exhaust Manifold

序号 No.	零部件图号 Part No.	名称 Name	Part Name	数量 Qty	备注 Remark
13	190003962014	六角头螺塞	Plug	1	
14	VG9003080003	复合密封垫圈	Gasket	1	
15	VG9003980002	强力卡箍	Clamp	2	
16	VG2600110824	带纤维夹层橡胶软管	Hose	1	
17	VG1560110165	连接弯管	Tube	1	
18	VG1560110226	夹子	Clip	1	
19	VG190320035	密封圈	Gasket	1	
20	VG2600111144	前隔热罩	Anti-heat cover	1	
21	VG2600110962	隔热罩螺栓	Bolt	8	
22	190003936109	大垫圈	Washer	14	
23	VG2600111145	后隔热罩		1	
24	190003862428	内六角圆柱头螺钉	Screw	2	
25	VG188250083	自锁垫圈	Washer	4	
26	VG1560110152	进油管法兰	Flange	1	
27	VG609E110050	进油管垫片	Gasket	1	
28	VG2600110048	回油管法兰垫片	Gasket	1	
29	VG1460070014	回油管螺栓	Bolt	2	
30	190003989340	软管卡箍	Hose clamp	2	
31	VG2600111428	双头螺柱M10X45 DIN939	Bolt	4	
32	190003888470	自锁螺母	Nut	4	

2.1.28 双缸水冷空压机/Air Compressor

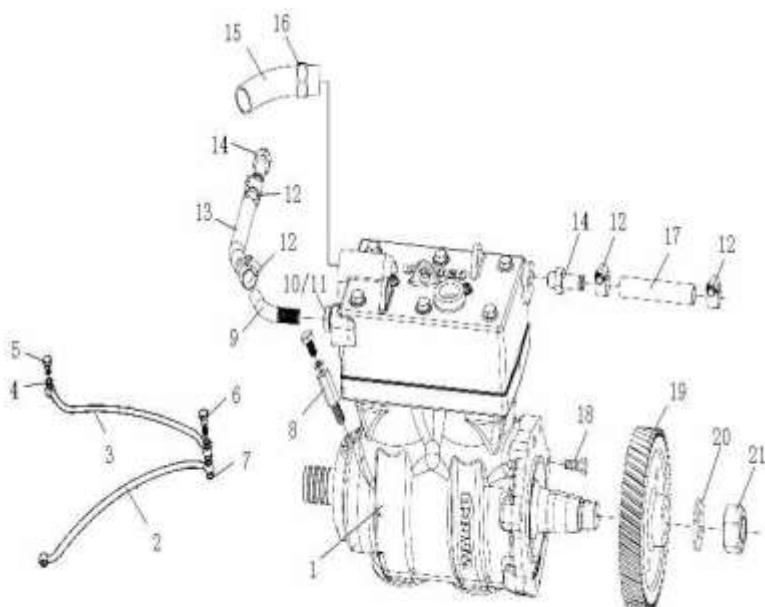

2.1.28 双缸水冷空压机/Air Compressor

序号	零部件图号	名称	Part Name	数量	备注
No.	Part No.			Qty	Remark
1	VG1093130001	双缸水冷空压机	Air compressor	1	
2	VG1560070060	高压油泵润滑油管总成	Tube assembly	1	
3	VG1560070050	空压机润滑油管总成	Tube assembly	1	
4	VG9003080003	复合密封垫圈	Gasket	2	
5	190003962607	空心螺栓	Hollow bolt	1	
6	VG1560070012	空心螺栓	Hollow bolt	1	
7	VG9003080003	复合密封垫圈	Gasket	3	
8	VG1560070051	过渡接头	Nozzle	2	
9	VG1560060012	空压机进水管接头	Nozzle	1	
10	VG2600080200	密封垫圈	Gasket	1	
11	Q351B14	六角薄螺母	Nut	1	
12	190003989336	软管卡箍	Hose clamp	4	
13	VG1560060019	国II空压机进水管(带纤维)	Hose	1	
14	VG2600130026	水冷空压机水管接头	Nozzle	2	
15	VG1560130035	空压机进气管接头	Nozzle	1	
16	190003559778	六角螺母	Nut	1	
17	VG1560060018	空压机出水管(带纤维夹片)	Hose	1	
18	Q1860830TF2	六角法兰面螺栓	Bolt	7	
19	VG1560130064	喷油泵齿轮	Gear	1	
20	VG409020045	垫片	Shim	1	

